

OPERATING AND SAFETY PRECAUTIONS

READ, UNDERSTAND, AND FOLLOW THIS INFORMATION TO AVOID INJURY AND PROPERTY DAMAGE.



⚠ WARNING EXCESSIVE AIR PRESSURE. Can cause personal injury, pump damage or property damage.

- Do not exceed the maximum inlet air pressure as stated on the pump model plate.
- Be sure material hoses and other components are able to withstand fluid pressures developed by this pump. Check all hoses for damage or wear. Be certain dispensing device is clean and in proper working condition.

⚠ WARNING STATIC SPARK. Can cause explosion resulting in severe injury or death. Ground pump and pumping system.

- Use the pump grounding screw terminal provided. Use Aro Part No. 66885-1 Ground Kit or connect a suitable ground wire (12 ga. min.) to a good earth ground source.
- Secure pump, connections and all contact points to avoid vibration and generation of contact or static spark.
- Consult local building codes and electrical codes for specific grounding requirements.
- After grounding, periodically verify continuity of electrical path to ground. Test with an ohmmeter from each component (e.g., hoses, pump, clamps, container, spray gun, etc.) to ground to insure continuity. Ohmmeter should show 100 ohms or less.
- Submerge the outlet hose end, dispensing valve or device in the material being dispensed if possible. (Avoid free streaming of material being dispensed.)
- Use hoses incorporating a static wire.
- Use proper ventilation.
- Keep inflammables away from heat, open flames and sparks.
- Keep containers closed when not in use.

⚠ WARNING Pump exhaust may contain contaminants. Can cause severe injury. Pipe exhaust away from work area and personnel.

- In the event of a diaphragm rupture material can be forced out of the air exhaust muffler.
- Pipe the exhaust to a safe remote location when pumping hazardous or inflammable materials.
- Use a grounded 1" min. i.d. hose between the pump and the muffler.

⚠ WARNING HAZARDOUS PRESSURE. Can result in serious injury or property damage. Do not service or clean pump, hoses or dispensing valve while the system is pressurized.

- Disconnect air supply line and relieve pressure from the system by opening dispensing valve or device and / or carefully and slowly loosening and removing outlet hose or piping from pump.

⚠ WARNING HAZARDOUS MATERIALS. Can cause serious injury or property damage. Do not attempt to return a pump to the factory or service center that contains hazardous material. Safe handling practices must comply with local and national laws and safety code requirements.

- Obtain Material Safety Data Sheets on all materials from the supplier for proper handling instructions.

⚠ WARNING EXPLOSION HAZARD. Models containing aluminum wetted parts cannot be used with III.-Trichloroethane, Methylene Chloride or other Halogenated Hydrocarbon solvents which may react and explode.

- Check pump motor section, fluid caps, manifolds and all wetted parts to assure compatibility before using with solvents of this type.

⚠ WARNING MISAPPLICATION HAZARD. Do not use models containing aluminum wetted parts with food products for human consumption. Plated parts can contain trace amounts of lead.

⚠ CAUTION Verify the chemical compatibility of the pump wetted parts and the substance being pumped, flushed or recirculated. Chemical compatibility may change with temperature and concentration of the chemical(s) within the substances being pumped, flushed or circulated. For specific fluid compatibility, consult the chemical manufacturer.

⚠ CAUTION Maximum temperatures are based on mechanical stress only. Certain chemicals will significantly reduce maximum safe operating temperature. Consult the chemical manufacturer for chemical compatibility and temperature limits. Refer to PUMP DATA on page 1 of this manual.

⚠ CAUTION Be certain all operators of this equipment have been trained for safe working practices, understand it's limitations, and wear safety goggles / equipment when required.

⚠ CAUTION Do not use the pump for the structural support of the piping system. Be certain the system components are properly supported to prevent stress on the pump parts.

- Suction and discharge connections should be flexible connections (such as hose), not rigid piped, and should be compatible with the substance being pumped.

⚠ CAUTION Prevent unnecessary damage to the pump. Do not allow pump to operate when out of material for long periods of time.

- Disconnect air line from pump when system sits idle for long periods of time.

⚠ CAUTION Use only genuine ARO replacement parts to assure compatible pressure rating and longest service life.

⚠ WARNING = Hazards or unsafe practices which could result in severe personal injury, death or substantial property damage.

⚠ CAUTION = Hazards or unsafe practices which could result in minor personal injury, product or property damage.

NOTICE = Important installation, operation or maintenance information.

AIR AND LUBE REQUIREMENTS

⚠ WARNING EXCESSIVE AIR PRESSURE. Can cause pump damage, personal injury or property damage.

- A filter capable of filtering out particles larger than 50 microns should be used on the air supply. There is no lubrication required other than the “O” ring lubricant which is applied during assembly or repair.
- If lubricated air is present, make sure that it is compatible with the Nitrile “O” rings in the air motor section of the pump.

OPERATING INSTRUCTIONS

- Always flush the pump with a solvent compatible with the material being pumped if the material being pumped is subject to “setting up” when not in use for a period of time.
- Disconnect the air supply from the pump if it is to be inactive for a few hours.
- The outlet material volume is governed not only by the air supply but also by the material supply available at the inlet. The material supply tubing should not be too small or restrictive. Be sure not to use hose which might collapse.
- When the diaphragm pump is used in a forced-feed (flooded inlet) situation it is recommended that a “Check Valve” be installed at the air inlet.
- Secure the diaphragm pump legs to a suitable surface to insure against damage by vibration.

MAINTENANCE

Refer to the part views and descriptions as provided on page 4 through 7 for parts identification and Service Kit information.

- Certain ARO “Smart Parts” are indicated which should be available for fast repair and reduction of down time.
- Service kits are divided to service two separate diaphragm pump functions: 1. AIR SECTION, 2. FLUID SECTION. The FLUID SECTION is divided further to match typical part MATERIAL OPTIONS.

MAINTENANCE (CONT'D)

- Provide a clean work surface to protect sensitive internal moving parts from contamination from dirt and foreign matter during service disassembly and reassembly.
- Keep good records of service activity and include pump in preventive maintenance program.
- Before disassembling empty captured material in the outlet manifold by turning the pump upside down to drain material from the pump.

FLUID SECTION DISASSEMBLY

1. Remove top manifold(s).
2. Remove (22) balls, (19) “O” rings and (21) seats.
3. Remove (15) fluid caps.
NOTE: Only Teflon diaphragm models use a primary (7) diaphragm and a backup (8) diaphragm. Refer to the auxiliary view in figure 1.
4. Remove the (6) diaphragm washer, (7) or (7 / 8) diaphragms, (5) backup washer and (196) cushion.
NOTE: Do not scratch or mar the surface of (1) diaphragm rod.

FLUID SECTION REASSEMBLY

SERVICE NOTE: ARO PN 204214-T Diaphragm Assembly Tool is recommended for use when reassembling the pump.

- Reassemble in reverse order.
- Clean and inspect all parts. Replace worn or damaged parts with new parts as required.
- Lubricate (1) diaphragm rod and (144) “U” cup with Lubriplate® FML-2 Grease. (94276 grease packet is included in service kit.)
- Be certain the diaphragm assembly bottoms out on the (1) rod, back off Teflon Diaphragm assembly far enough to align holes.
- For models with Teflon diaphragms: Item (8) Santoprene diaphragm is installed with the side marked “AIR SIDE” towards the pump center body. Install the (7) Teflon Diaphragm with the side marked “FLUID SIDE” towards the fluid cap.
- Re-check torque settings after pump has been re-started and run a while.

PARTS LIST / PM30X-X-X-B02 FLUID SECTION

FLUID SECTION SERVICE KITS (637303-XX)

★ KITS INCLUDE: BALLS (See Ball Option, refer to -XX in chart below), DIAPHRAGMS (See Diaphragm Option, refer to -XX in chart below), and items; 3, 19, 70, 144, 175, 196, (listed below) plus (174) and 94276 Lubriplate FML-2 grease (page 6).

SEAT OPTIONS PM30X-CSS-XXX-B02

"21"				★ "19"		
-XXX	SEAT	QTY	[MTL]	GASKET	QTY	[MTL]
-AXX	94104-A	(4)	[SP]	-----	---	---
-SAX	94113	(4)	[SS]	94115	(4)	[E]
-STX	94113	(4)	[SS]	Y328-350	(4)	[T]

BALL OPTIONS PM30X-CSS-XXX-B02

★ "22" (3.25" dia.)		
-XXX	BALL (4)	[MTL]
-XAX	94103-A	[SP]
-XTX	94103-T	[T]

DIAPHRAGM OPTIONS PM30X-CSS-XXX-B02

★ SERVICE KIT		★ "7" / "8"	
-XXX	-XX = (Ball) -XX = (Diaphragm)	DIAPHRAGM (2)	[MTL]
-XXA	637303-XA	94091-A	[SP]
-XXT	637303-XT	94090-T / 94110-A	[T/SP]

MATERIAL CODE

[A] = Aluminum
[B] = Nitrile
[C] = Carbon Steel
[Co] = Copper
[E] = E.P.R.
[SP] = Santoprene
[SS] = Stainless Steel
[T] = Teflon

CENTER SECTION PART OPTIONS PM30X-

ITEM	DESCRIPTION (Size in inches)	Qty	PM30S-X		PM30A-X	
			PART NO.	[MTL]	PART NO.	[MTL]
5	Backup Washer	(2)	94831-2	[SS]	94831-1	[C]
68	Air Cap	(1)	94031-1	[SS]	94030-1	[A]
69	Air Cap	(1)	94031-2	[SS]	94030-2	[A]
★ 175	"O" Ring (3/32" x [1-1/16" o.d.] / [2-1" o.d.])	(2)	Y325-118 ①	[B]	Y325-117 ②	[B]

COMMON PARTS

ITEM	DESCRIPTION (Size in inches)	Qty	PART NO.	[MTL]	ITEM	DESCRIPTION (Size in inches)	Qty	PART NO.	[MTL]
1	Rod	(1)	94984	[C]	43	Ground Lug	(1)	93004	[Co]
★ 3	"O" Ring (1/8" x 1" o.d.)	(2)	Y328-210	[T]	60	Outlet Manifold	(1)	94969	[SS]
6	Fluid Side Washer	(2)	94803	[SS]	61	Inlet Manifold	(1)	94968	[SS]
9	Washer (3/16" i.d. x 2" o.d. x 5/32")	(2)	Y13-12-T	[SS]	★ 70	Gasket	(2)	94100	[B]
14	Cap Screw (3/4" - 16 x 3-1/4")	(2)	Y5-134-T	[SS]	126	Pipe Plug (1/4 - 18 N.P.T. x 7/16")	(2)	Y17-51-S	[SS]
15	Fluid Cap	(2)	94972	[SS]	131	Screw (M10 x 1.5 - 6g x 120 mm)	(4)	94531	[C]
26	Screw (M12 x 1.75 - 6g x 45 mm)	(12)	94412-2	[SS]	★ 144	"U" Cup (3/16" x 1-3/8" o.d.)	(2)	Y186-51	[B]
27	Screw (M12 x 1.75 - 6g x 60 mm)	(16)	94991	[SS]	180	Gasket (.406" i.d. x .031" thick)	(4)	94098	[Co]
29	Nut (M12 x 1.75 - 6g)	(16)	95053	[SS]	★ 196	Cushion	(2)	94631	[SP]
32	Leg	(2)	94703-2	[SS]					

☐ "Smart Parts" keep these items on hand in addition to the Service Kits for fast repair and reduction of down time.

PARTS LIST / PM30X-X-X-B02 FLUID SECTION

FOR THE
AIR MOTOR SECTION
SEE PAGES 6 & 7

COLOR CODE		
MATERIAL	DIAPHRAGM	BALL COLOR
SANTOPRENE	TAN	TAN
SANTOPRENE (BACKUP)	GREEN	N/A
TEFLON	WHITE	WHITE

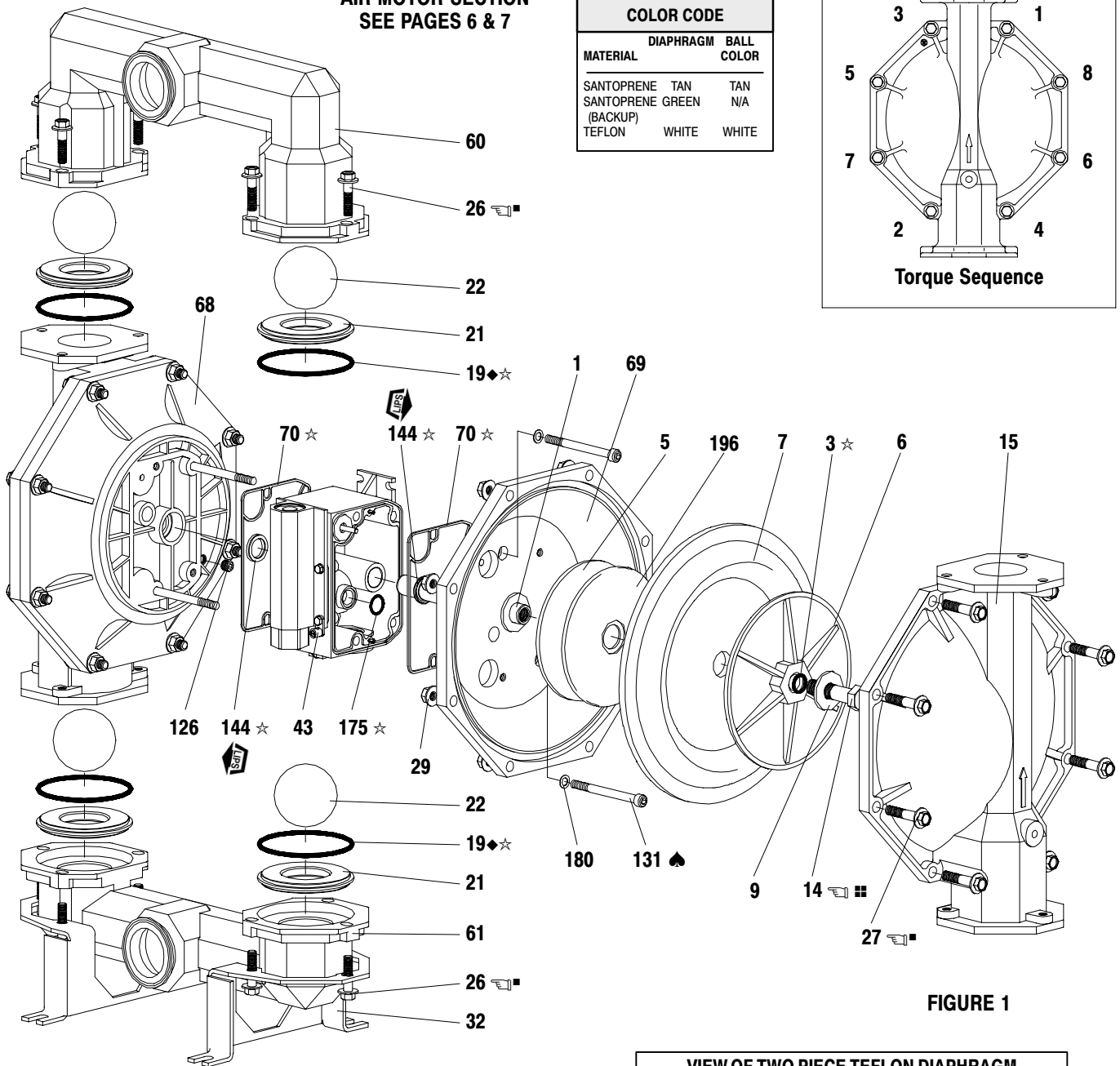
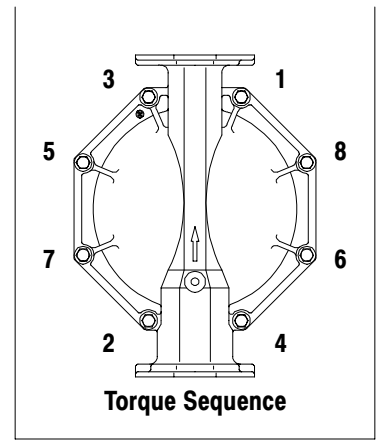

FIGURE 1

TORQUE REQUIREMENTS

NOTE: DO NOT OVERTIGHTEN FASTENERS
ALL FASTENERS ARE METRIC

(14) Cap Screw 60 - 70 ft lbs (81.4 - 94.9 Nm)
 (26, 27) Fluid Caps / Manifold Screw 60 - 70 ft lbs (81.4 - 94.9 Nm),
 ■ Apply Loctite 204 to threads.

■ Apply anti-seize compound to threads when using
 SS fasteners and stainless steel wet ends.

LUBRICATION / SEALANTS

☆ Apply Lubriplate FML-2 Grease to all
 "O" rings, "U" Cups & mating parts.
 ◆ USED WITH -SXX ONLY
 ♣ Apply Loctite 242 to threads at assembly.

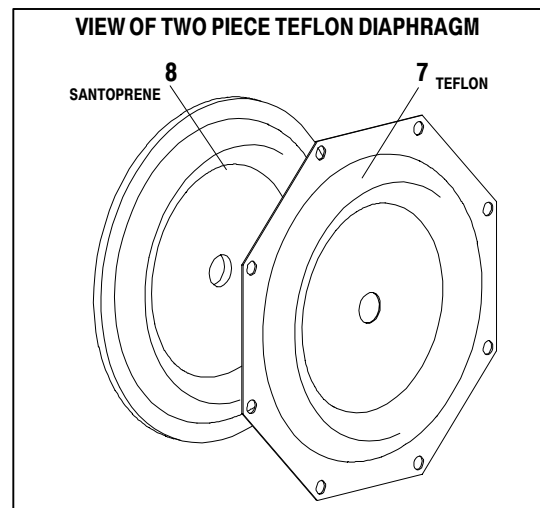

◆ Lubriplate FML-2 is a white food grade petroleum grease. MSDS available upon request.

PARTS LIST / PM30X-X-X-B02 AIR SECTION

✓ Indicates parts included in 637302 Air Section Service Kit shown below and items (70), (144), (175) and (180) shown on page 4.

AIR MOTOR PARTS

ITEM	DESCRIPTION (Size in inches)	Qty	PART NO.	[MTL]
101	Center Body (PM30S-X)	(1)	94109	[SS]
	(PM30A-X)	(1)	94028	[A]
103	Bushing	(1)	94092	[D]
107	Inlet Plug	(1)	94034-2	[SS]
109	Piston	(1)	92011	[D]
✓ 110	“U” Cup (1-3/8” o.d.) (Also Item #144)	(1)	Y186-51	[B]
111	Spool (PM30S-X)	(1)	93047	[C]
	(PM30A-X)	(1)	92005	[A]
112	Washer (1.556” o.d.)	(5)	92877	[Z]
✓ 113	“O” Ring (small) (1/8” x 1-1/4” o.d.)	(5)	Y325-214	[B]
✓ 114	“O” Ring (large) (3/32” x 1-9/16” o.d.)	(7)	Y325-126	[B]
□ 115	Spacer	(4)	92876	[Z]
116	Spacer	(1)	94027	[A]
118	Actuator Pin (.250” x 2.276”)	(2)	94083	[SS]
121	Sleeve	(2)	94084	[D]
✓ 132	Gasket (Valve Body)	(1)	94099	[B]
133	Lockwasher (1/4”)	(3)	Y14-416-T	[SS]
134	Screw (M6 x 1.0 x 16 mm)	(4)	96720081	[SS]

ITEM	DESCRIPTION (Size in inches)	Qty	PART NO.	[MTL]
135	Valve Block (PM30S-X)	(1)	94318	[SS]
	(PM30A-X)	(1)	94032	[A]
136	Piston Plug	(1)	94033-1	[UH]
✓ 146	“O” Ring (3/32” x 1-1/16” o.d.)	(1)	Y325-118	[B]
✓ 147	“O” Ring (1/8” x 1/2” o.d.) Also #174	(2)	Y325-202	[B]
✓ 167	Pilot Piston (includes 168 and 169)	(1)	67164	[D]
168	“O” Ring (3/32” x 5/8” o.d.)	(2)	94433	[U]
169	“U” Cup (1/8” x 7/8” o.d.)	(1)	Y240-9	[B]
170	Piston Sleeve	(1)	94081	[Br]
✓ 171	“O” Ring (3/32” x 1-1/8” o.d.)	(1)	Y325-119	[B]
✓ 172	“O” Ring (1/16” x 1-1/8” o.d.)	(1)	Y325-22	[B]
✓ 173	“O” Ring (1/16” x 1-3/8” o.d.)	(2)	Y325-26	[B]
★✓ 174	“O” Ring (1/8” x 1/2” o.d.)	(2)	Y325-202	[B]
✓ 176	Diaphragm (Check Valve)	(2)	94102	[SP]
✓ 177	Retaining Ring (1.804” dia.)	(1)	Y147-16-S	[SS]
181	Roll Pin (.156 o.d. x 3/4” long)	(4)	Y178-56-S	[SS]
★✓	Lubriplate FML-2 Grease	(1)	94276	
	Lubriplate Grease Packets (10)		637308	

AIR MOTOR SECTION SERVICE

Service is divided into two parts – 1. Pilot Valve, 2. Major Valve.

GENERAL REASSEMBLY NOTES:

- Air Motor Section Service is continued from Fluid Section repair.
- Inspect and replace old parts with new parts as necessary. Look for deep scratches on metallic surfaces, and nicks or cuts in “O” rings.
- Take precautions to prevent cutting “O” rings upon installation.
- Lubricate “O” rings with Lubriplate FML-2 Grease.
- Do not over-tighten fasteners, refer to torque specification block on view.
- Re-torque fasteners following restart.
- SERVICE TOOLS – To aid in the installation of (168) “O” rings onto the (167) pilot piston, use Tool # 204130-T, available from Aro.

PILOT VALVE DISASSEMBLY

1. A light tap on (118) should expose the opposite (121) sleeve, (167) pilot piston and other parts.
2. Remove (170) sleeve and inspect inner bore of sleeve for damage.

PILOT VALVE REASSEMBLY

1. Clean and lubricate parts not being replaced from service kit.
2. Install new (171 and 172) “O” rings, replace (170) sleeve.
3. Install new (168) “O” rings and (169) seal – Note the lip direction. Lubricate and replace (167).
4. Reassemble remaining parts, replace (173 and 174) “O” rings.

MATERIAL CODE

[A] = Aluminum	[D] = Acetal	[UH] = UHMW-PE
[B] = Nitrile	[SP] = Santoprene	[Z] = Zinc
[Br] = Brass	[SS] = Stainless Steel	
[C] = Carbon Steel	[U] = Polyurethane	

MAJOR VALVE DISASSEMBLY

1. Remove (135) valve block, exposing gaskets (166 and 132) and (176) checks.
2. Remove (177) snap ring and (107) inlet plug.
3. On the side opposite the air inlet, push on the inner diameter of (111) spool. This will force the (136) piston plug and (109) piston out. Continue pushing the (111) spool and remove. Check for scratches or gouges.
4. Remove the Major Valve parts (112 - 116).

MAJOR VALVE REASSEMBLY

1. Replace (112) washer, (114) “O” ring and (113) “O” ring onto (115) spacer and insert etc. Continue this routine to build the major valve stack.
- NOTE: Be careful to orient spacer legs away from blocking internal ports.**
2. Replace (111) spool on (136) plug, (110) seal on (109) piston and replace (109), (136) plug and (177) snap ring.

PARTS LIST / PM30X-X-X-B02 AIR SECTION

MAJOR VALVE CROSS SECTION DETAIL

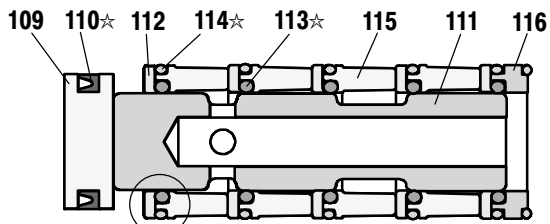
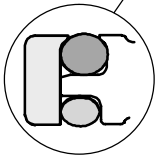

FIGURE 3



PILOT VALVE PART GROUP

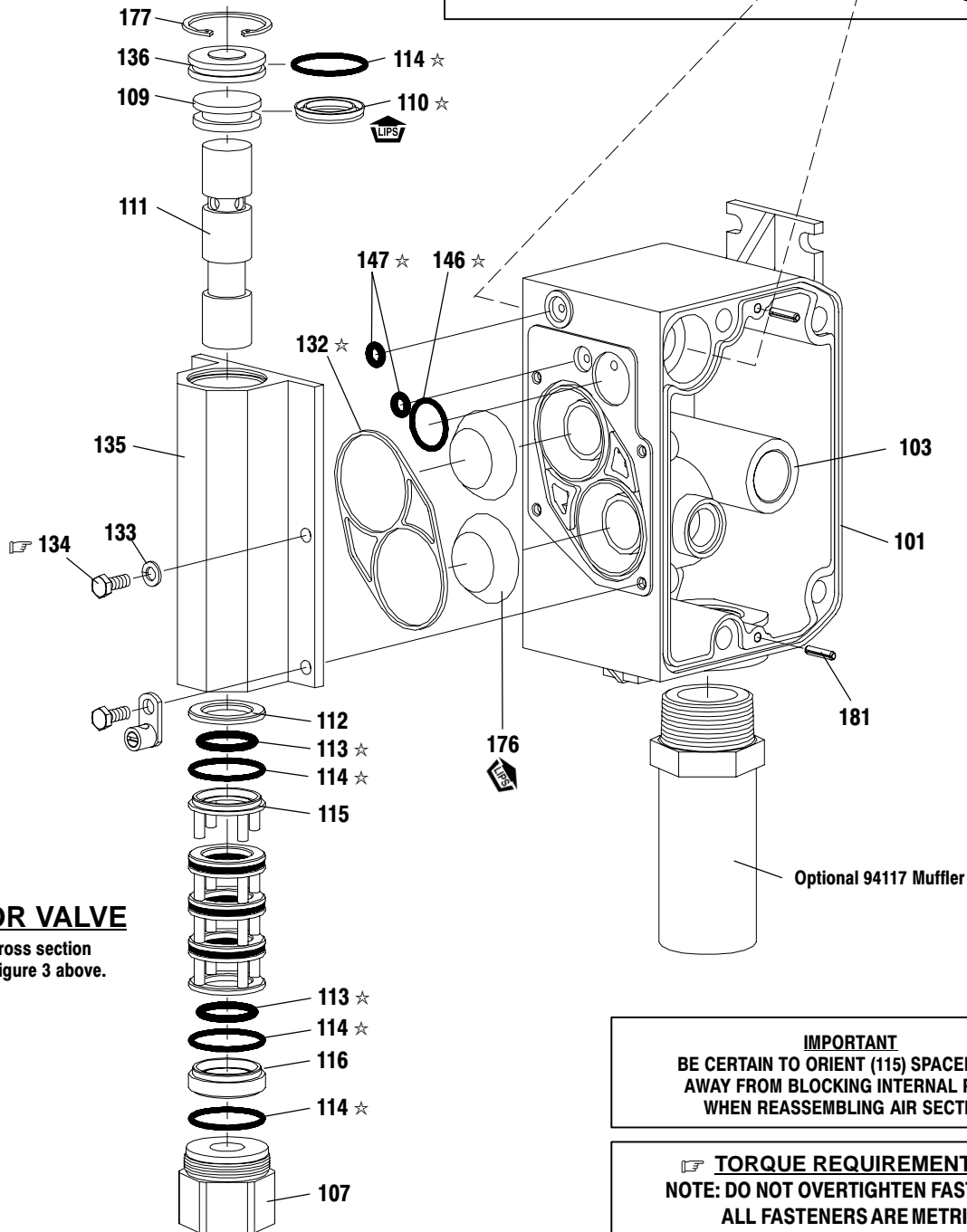
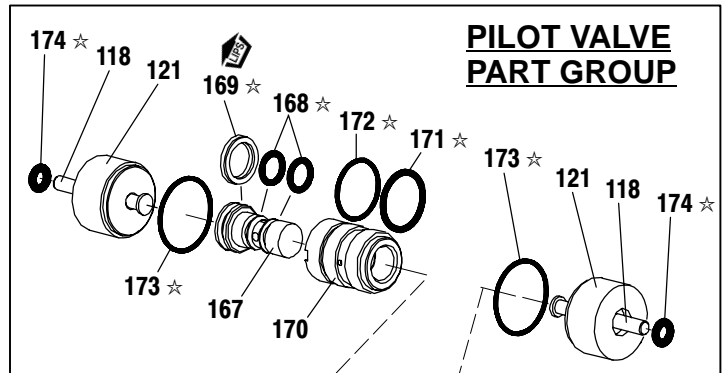

FIGURE 2

MAJOR VALVE

See cross section detail Figure 3 above.

A Replacement Major Valve Service Assembly is available separately which includes the following.
 Valve Assembly Items Included
 67089-2 107 - 116, 132, 135, 136, 146, 147, 176, 177

IMPORTANT
 BE CERTAIN TO ORIENT (115) SPACER LEGS AWAY FROM BLOCKING INTERNAL PORTS WHEN REASSEMBLING AIR SECTION.

TORQUE REQUIREMENTS
 NOTE: DO NOT OVERTIGHTEN FASTENERS
 ALL FASTENERS ARE METRIC
 Torque (134) Screw to 40 - 50 in. lbs (4.5 - 5.6 Nm)

LUBRICATION / SEALANTS
 ☆ Apply Lubriplate FML-2 Grease to "O" rings, "U" Cups & mating parts.

TROUBLE SHOOTING

Product discharged from exhaust outlet.

- Check for diaphragm rupture.
- Check tightness of diaphragm nut.

Air bubbles in product discharge.

- Check connections of suction plumbing.
- Check "O" rings between intake manifold and fluid caps.
- Check tightness of diaphragm nut.

Motor blows air or stalls.

- Check (176) check valve for damage or wear.
- Check for restrictions in valve / exhaust.

Low output volume, erratic flow, or no flow.

- Check air supply.
- Check for plugged outlet hose.
- Check for kinked (restrictive) outlet material hose.
- Check for kinked (restrictive) or collapsed inlet material hose.
- Check for pump cavitation - suction pipe should be sized at least as large as the inlet thread diameter of the pump for proper flow if high viscosity fluids are being pumped. Suction hose must be a non-collapsing type, capable of pulling a high vacuum.
- Check all joints on the inlet manifolds and suction connections. These must be air tight.
- Inspect the pump for solid objects logged in the diaphragm chamber or the seat area.

DIMENSIONAL DATA

(Dimensions shown are for reference only, they are displayed in inches and millimeters (mm).)

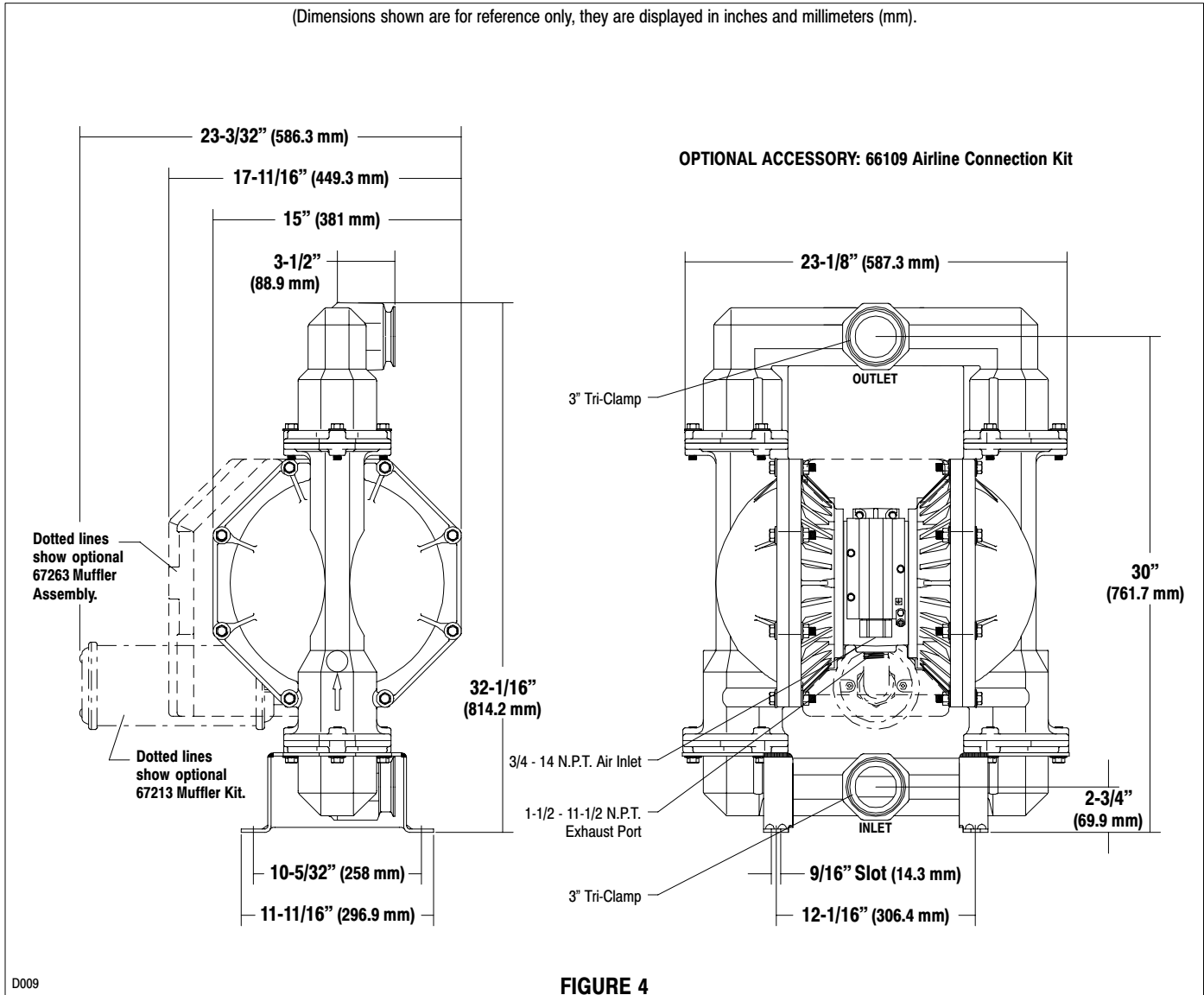

D009



PN 97999-848